

# **PTP650 Synchronous Ethernet and IEEE1588 Primer**

## Table of Contents

<b>3</b>	<b>Ethernet in Cellular Backhaul</b>
3	Timing Options for Ethernet Cellular Backhaul
<b>4</b>	<b>Synchronous Ethernet</b>
4	What is Synchronous Ethernet?
4	Synchronous Ethernet on PTP 650
<b>5</b>	<b>Precision Time Protocol</b>
5	What is Precision Time Protocol?
<b>6</b>	<b>PTP Timing Transfer</b>
6	One-step and Two-step Time Stamps
<b>7</b>	<b>Profiles</b>
7	PTP Timing Impairments
<b>7</b>	<b>IEEE1588 Protocol on PTP 650</b>
7	PTP 650 Operates as a Transparent Clock
<b>8</b>	<b>Other Applications for IEEE1588</b>
<b>8</b>	<b>The Bloggers Guide to Synchronous Ethernet and IEEE1588</b>

## Ethernet in Cellular Backhaul

All cellular networks require a very accurate frequency reference. TDD networks, such as WiMAX and Long Term Evolution (LTE), additionally need an accurate phase reference. Advanced LTE techniques need an accurate phase reference regardless of whether they are in FDD or TDD networks.

3G operators have traditionally used TDM e.g. E1 or T1, to provide a frequency reference. TDM can provide frequency synchronisation but not phase or time. Although a TDM sourced frequency reference is suitable for 2G & 3G deployments it does not meet the requirements of Advanced LTE because these advanced features need time synchronisation.

The timing challenge for the cellular operator is a desire to migrate to Ethernet for capacity and economy, whilst maintaining accurate frequency, phase and time references.

### TIMING OPTIONS FOR ETHERNET CELLULAR BACKHAUL

The alignment of clocks to the same frequency is called **syntonisation**. The alignment of clocks to the same frequency and phase is **synchronisation**. **Time of day synchronisation**, is the alignment of clocks to the same frequency & phase and to a common time origin.

The cellular backhaul needs to transport both frequency, phase and time. The options for the operator are Global Navigation Satellite System (GNSS) receivers (e.g. GPS), Synchronous Ethernet and Precision Time Protocol.

- **GNSS** is a mature and widely deployed technology. It provides an accurate frequency, phase & time reference but it is vulnerable to deliberate, accidental or reckless jamming, and there are many cellular deployments (for example indoors or in subway tunnels) where it is difficult to deploy GNSS with a view of the sky. CDMA networks have generally used GNSS to provide an accurate network-wide reference but the cost and complexity of GNSS deployments can make it unattractive.
- **Synchronous Ethernet** can provide syntonisation but requires all the equipment in the network to support clock transport. It provides a high quality frequency reference that is not affected by traffic load but it cannot be used to transport phase or time.
- **Precision Time Protocol (IEEE1588-2008)** uses a packet based protocol to transport both frequency, phase and time, across existing network equipment, from a master time reference to multiple slave clocks. A significant characteristic of PTP is that the protocol allows for hardware time stamping and residence time correction. This is what elevates PTP above NTP v3.

These options should not be considered mutually exclusive and, in many cases, a combination of GNSS, Synchronous Ethernet and Precision Time Protocol will produce the most robust and accurate timing solution.

**Synchronous Ethernet and Precision Time Protocol are NOT the same.**

# Synchronous Ethernet

## WHAT IS SYNCHRONOUS ETHERNET?

**Synchronous Ethernet**, often referred to as **SyncE**, transfers frequency over the Ethernet physical layer utilising the Ethernet symbol clock in a similar way to SONET/SDH Layer 1 clocks. For SyncE to work, all device hardware between the endpoints must support the transportation of this symbol clock. It often cannot be deployed on legacy Ethernet networks unless some or all of the hardware is upgraded. Synchronous Ethernet does not transfer time of day or phase through a network.

SyncE was standardized by the ITU-T in three recommendations

1. ITU-T Rec. G.8261 defines the architecture and the wander performance of SyncE networks
2. ITU-T Rec. G.8262 specifies Synchronous Ethernet clocks for SyncE
3. ITU-T Rec. G.8264 specifies the Ethernet Synchronisation Messaging Channel (ESMC)

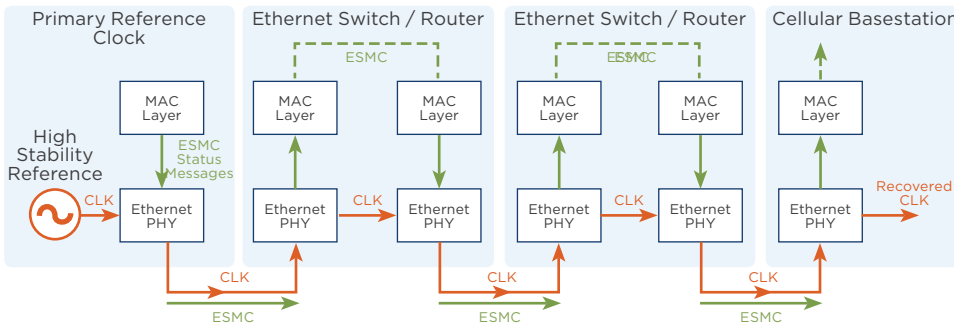

Figure 1 : Clock and ESMC Propagation in Synchronous Ethernet

All devices in the SyncE network must have a clock source, as shown in orange in Figure 1, traceable to a **Primary Reference Clock (PRC)**, creating a timing hierarchy as shown in Figure 2. Status messages are generated by the upstream SyncE devices, as shown in green in Figure 1. These messages indicate clock quality and failure status to the downstream devices, allowing these downstream devices to select

the best available timing source. This selection is performed using the **Ethernet Synchronisation Messaging Channel (ESMC)** protocol into which SONET/SDH style **Sync Status Messages (SSM)** are encoded. By embedding SSM in this way, SyncE and SDH networks are able exchange information about the synchronisation source.

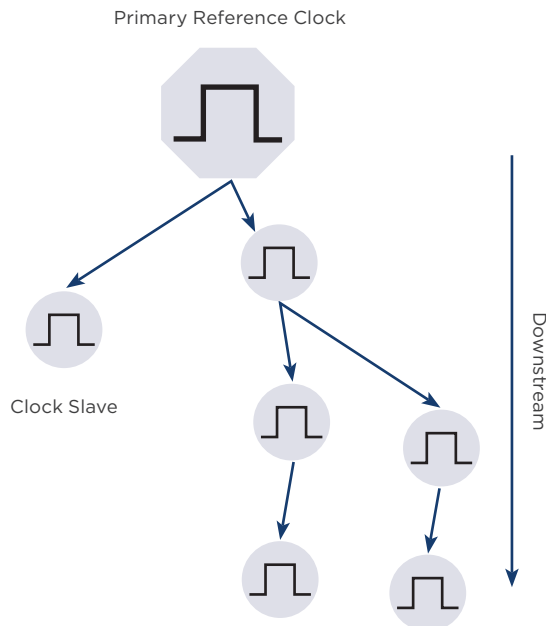

Figure 2 : Synchronous Ethernet Hierarchy

## SYNCHRONOUS ETHERNET ON PTP 650

PTP 650 has the hardware to support the transfer of the SyncE frequency reference from one side of the radio link to the other. When SyncE is enabled on the PTP 650, the unit will respond to and generate ESMC messages. This allows PTP 650 to be successfully deployed in a SyncE network to transfer both the frequency and the status messages required by the network operator. This is shown in Figure 3.

PTP 650 is designed to meet the following SyncE specifications

1. G.8262/Y.1362 (07/10) Timing characteristics of a synchronous Ethernet equipment slave clock.
2. G.8262/Y.1362 (10/2012) Timing characteristics of a synchronous Ethernet equipment slave clock: Amendment 2.

# Precision Time Protocol

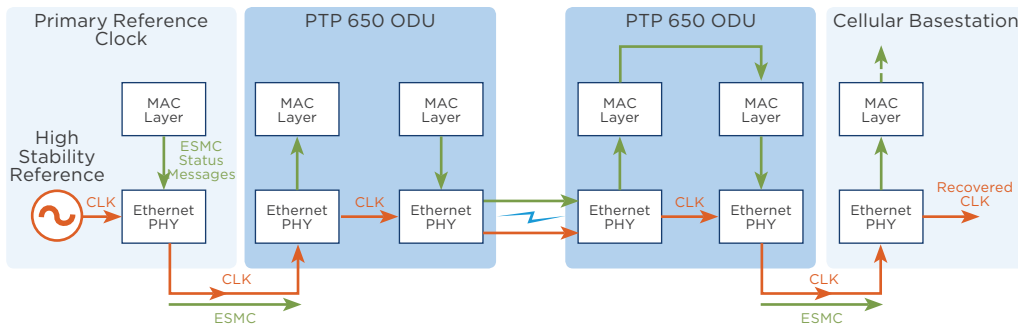

Figure 3: PTP 650 Operating in Synchronous Ethernet Network

## WHAT IS PRECISION TIME PROTOCOL?

Precision Time Protocol is defined in IEEE1588-2008, commonly referred to as 1588v2.

Precision Time Protocol (PTP) (and not to be confused with Point-To-Point), defines a master-slave hierarchy to transport frequency, phase and

time in dedicated timing packets across a packet network, from a single point in the network, known as a master clock, to multiple slave clocks. Slave clocks are kept synchronised by the transmission of time stamps sent within the PTP messages. The slave clocks recover the time, aligned with the master, to achieve synchronisation.

The earlier PTP deployments were offered as a replacement for TDM timing and as such provided syntonisation only. This is relatively easy to achieve if the slave clock has a stable reference and the tracking loop has a long time constant.

Additions to the 2008 version of the PTP standard help overcome the effects of latency and jitter through the network. Network devices that have a hardware time stamping capability allow PTP networks to synchronise with the nanosecond accuracy required by telecom operators. PTP deployments are now considered viable for frequency, phase and time transfer offering an alternative to GNSS.

IEEE1588-2008 defines a number of different types of clocks

- An **ordinary clock** is a device with a single port connection that can act as a **master clock** or **slave clock**. A master clock provides the accurate time reference to slave clocks where the root timing reference is called the **grandmaster clock**. Slave clocks recover the master timing and are very often embedded in cellular base stations or other network equipment.
- A **boundary clock** has multiple network port connections. Each port can be considered as an ordinary clock, where upstream ports are acting as a slave clock and downstream ports are acting as a master clock.
- A **transparent clock** has multiple network port connections but it does not act as either a master or slave clock. Rather it modifies a correction field within the PTP event messages with the total time these frames were resident within the network device. This is known as residence time correction. By performing residence time correction, transparent clocks decrease switch latency and jitter, thus making network devices appear **transparent** to ordinary clocks, therefore reducing slave clock time errors.

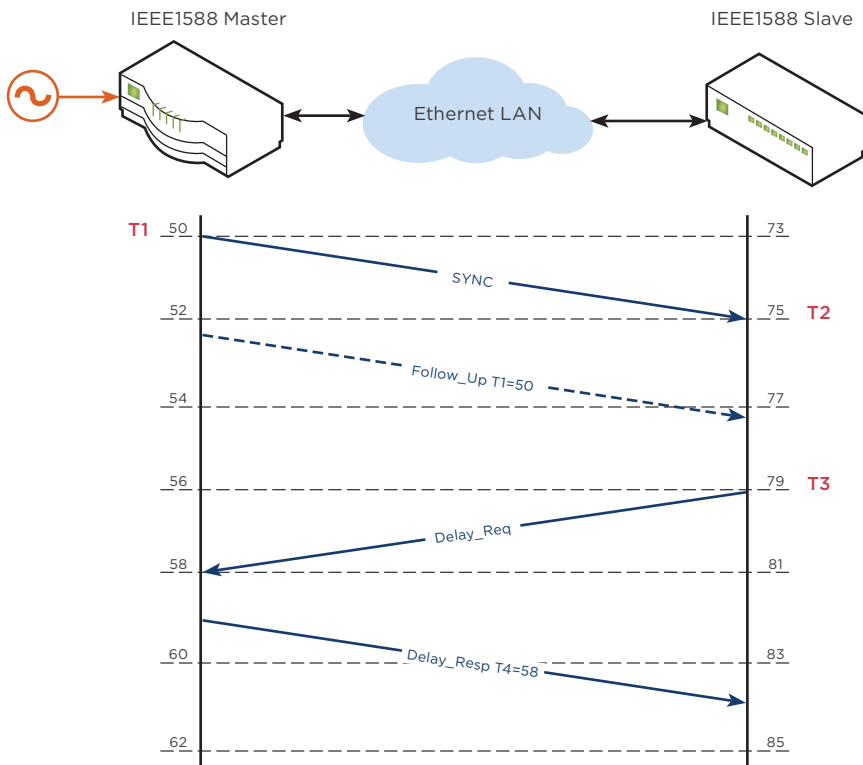

Figure 4 : PTP Message Transfer

## PTP TIMING TRANSFER

Synchronisation is achieved by the exchange of PTP messages as shown in the Figure 4

- **Sync** - This message passes from master to slaves. It is time stamped by the master on transmission (T1) and by the slave on arrival (T2).
- **Follow\_Up** - This message passes from the master to slave immediately after a Sync message and contains master time stamp value (T1). The slave now has the transmission time measured using the master clock. Follow-Up messages are not present when a one-step transparent clock is implemented.
- **Delay\_Request** - This message passes from slave to master. It is time stamped by the slave on transmission (T3) and the master on arrival (T4).
- **Delay\_Response** - This message passes from the master to slave, as a response to the Delay\_Request message and contains master time stamp value (T4).

Assuming that the transit delay in the master-slave direction and slave-master direction are equal, the offset can be calculated from the time stamps using the formula

$$\text{Offset} = ((T2-T1) - (T4-T3))/2$$

In the example, the clocks are initially offset by 23 seconds. The time stamp values are T1 = 50, T2=75, T3=79 and T4 = 58, so using the above formula the offset can be calculated as

$$\text{Offset} = ((75-50)-(58-79))/2 = 23\text{s}$$

As the master and slave clocks drift independently, regularly repeating the offset correction keeps the clocks synchronised.

In addition to the above message types, the PTP protocol defines management messages that transport information between the master and slave such as clock quality.

## ONE-STEP AND TWO-STEP TIME STAMPS

The IEEE1588-2008 standard allows for the time stamps passed between master and slave clocks to be either one-step or two-step. One-step clocks update the time stamp within the Sync messages on-the-fly, whilst two-step clocks transfer the time stamps in separate Follow-up messages. For example, Figure 4 shows a two-step clock but a similar diagram with a one-step clock would simply not have a Follow-up message. One-step clocks require hardware capable of on-the-fly updates of the correction field whereas two-step clocks must store time stamps and match them to the appropriate Follow-up messages.

## PROFILES

The PTP standard is very flexible and offers many optional features. This flexibility can lead to interoperability issues. Profiles have been created to define how these features are selected for a given application. To date, profiles have been created by the standards bodies and industry trade associations to include two default PTP profiles, a telecom profile and power industry profile. Other profiles are under development.

## PTP TIMING IMPAIRMENTS

PTP is operated over packet networks and therefore PTP packets will suffer network impairments including packet loss, out of order messages, packet delay and packet jitter. Packets will often be subject to different transit delays in master-slave direction compared to the slave-master direction. As the PTP protocol assumes that the transit delay in the master-slave direction and slave-master direction are equal, any path asymmetry that produces different transit delays results in a timing offset that is difficult for the slave clock to correct. Transparent clocks help reduce the impact of network impairments by providing the slave clock with an accurate residence time correction that will nullify the path asymmetry. This will result in reduced timing jitter, increased slave clock accuracy and improved slave clock stability in a real network.

Cellular timing requirements are stringent, with accuracy of around  $\pm 1$   $\mu$ s required at LTE small cell base stations. This can only be achieved with PTP if every node between the master and the slave is either a boundary block or a transparent clock where the time error contribution from each node is 50 ns or less. A network of this type is said to have “full on-path support”, i.e. all network elements are timing aware”.

## IEEE1588 PROTOCOL ON PTP 650

The accuracy of a slave clock will depend on the ability of the slave clock algorithm to cope with

- The delay asymmetry caused by network traffic load and varying network paths.
- The inaccuracy of the time stamps.

## PTP 650 Operates as a Transparent Clock

TDD microwave radio links pose a particular problem for frequency, phase and time transfer using PTP. Whilst adaptive modulation always ensures that maximum throughput is achieved in varying wireless conditions, it creates a dynamically changing link throughput. Coupled with an adaptive TDD structure and varying traffic load, PTP frames are subjected to packet delay variation, path asymmetry and occasional frame loss. There are claims that correctly prioritising PTP traffic can compensate for a lack of PTP support but there is no substitute for providing IEEE1588-2008 transparent clock functionality on a TDD microwave link. Without transparent clock functionality backed by hardware time stamping, the PDV introduced by the TDD system will greatly impact the accuracy achievable at a slave clock.

PTP 650 provides transparent clock functionality as shown in Figure 5. PTP 650 includes the capability to provide the accurate hardware time stamping needed to meet the timing requirements requested by cellular operators. For a 45MHz channel and Ethernet operating at 1G, the PTP 650 residence accuracy will be within 100ns and the resulting contribution to the long term timing error<sup>1</sup> at a slave clock will be less than 50ns.

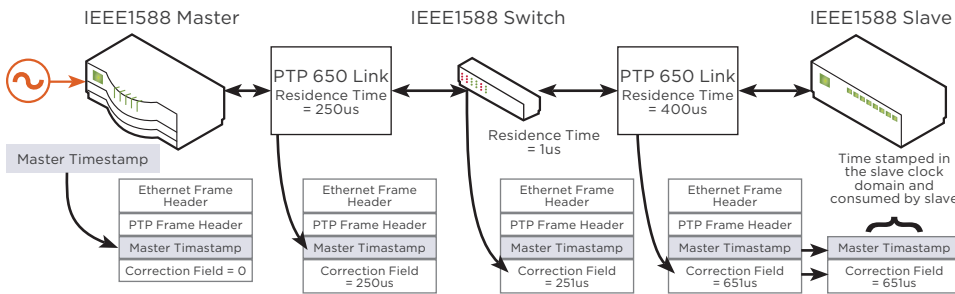

Figure 5 : PTP 650 Transparent Clock Operation

If the network supports both SyncE and PTP with a common or similar reference, then it is possible to combine the SyncE frequency reference with the hardware time stamping to further improve the residence time correction accuracy of the PTP 650. This will be particular evident when PTP event frame latencies are high.

### OTHER APPLICATIONS FOR IEEE1588

Although this paper has focused on telecommunications networks, precise time transfer is useful in many other applications where PTP 650 could be used to provide network infrastructure. Examples are

- Financial compliance and high frequency trading
- Electricity supply networks
- General test and instrumentation such as aircraft flight trials or seismology
- Industrial processes

## The Bloggers Guide to Synchronous Ethernet and IEEE1588

**Synchronous Ethernet (SyncE)** transfers frequency over the Ethernet physical layer utilising the Ethernet symbol clock. For SyncE to work, all device hardware between the endpoints must support the transportation of this symbol clock.

**Precision Time Protocol (PTP)** defines a master-slave hierarchy to transport time & frequency in dedicated timing packets across a packet network. It is defined in the IEEE specification IEEE1588-2008 but is often referred to as 1588v2 (version one is 1588-2002) or just 1588.

**Syntonsation** is the process of setting the frequency of one clock equal to that of another. These clocks may be out-of-phase and have no time-alignment.

**Synchronisation** is the process of setting the frequency and phase of one clock, equal to that of another.

**Time of Day Synchronisation** is achieved with two clocks that are synchronised and share the same epoch.

**Epoch** is the origin of a timescale. Time measurement units are counted from the epoch so that the date and time of events can be specified unambiguously.

<sup>1</sup> cTE using a 10s moving average filter with clock syntonisation to a SyncE source and a latency for the PTP event frames of less than 5ms.



Clocks that are **syntonised, synchronised** and have **time of day synchronisation** are shown in Figure 6.

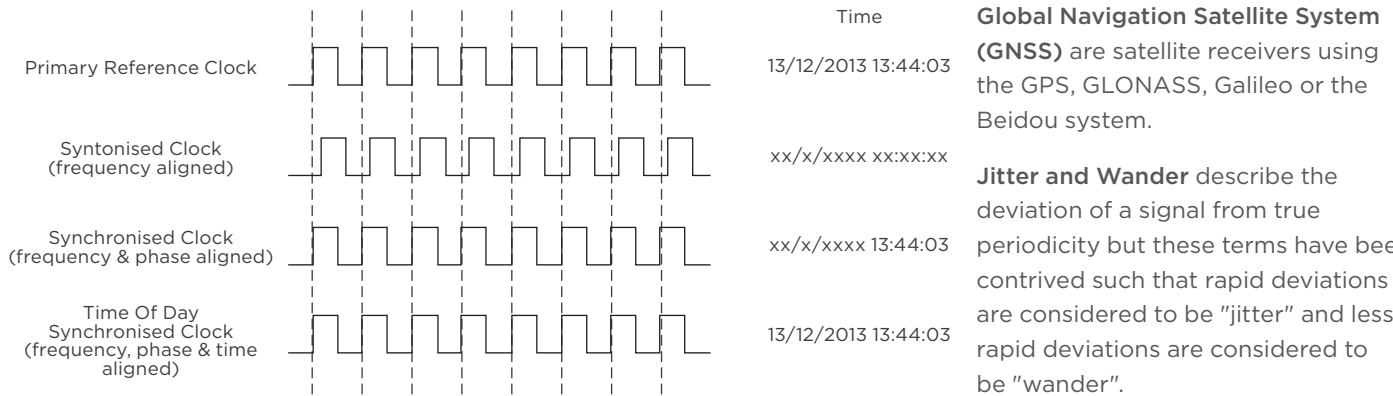

Figure 6 : Syntonisation, Synchronisation and ToD Synchronisation

**Global Navigation Satellite System (GNSS)** are satellite receivers using the GPS, GLONASS, Galileo or the Beidou system.

**Jitter and Wander** describe the deviation of a signal from true periodicity but these terms have been contrived such that rapid deviations are considered to be "jitter" and less rapid deviations are considered to be "wander".

- **Jitter** is the deviation of a signal from true periodicity with respect to a reference clock source. Jitter can be

thought of as the continual moving backwards and forwards of a signal with respect to an ideal clock source. Jitter is defined in the ITU-T G.810 standard as phase variation with frequency components greater than or equal to 10 Hz. Jitter is measured with reference to a clock extracted from the data signal and expressed in Unit Intervals (UI), which is equal to one data bit width.

- **Wander** is defined as the long term signal variations which change at a rate less than 10 Hz. It is measured with reference to an external reference clock and expressed in seconds or more commonly nanoseconds. Wander is typically measured with Time Interval Error (TIE) and derived metrics such as MTIE and TDEV.

**Time Interval Error (TIE)** is defined as a phase difference between the measured signal and the reference clock. TIE is set to zero at the start of the measurement period T so that it shows the phase change since the measurement began.

**Maximum Time Interval Error (MTIE)** measures the worst case phase variation of a signal with respect to a reference clock over a given period of time known as the observation time. MTIE can be considered to be the peak value of TIE during the observation time.

**Time Deviation (TDEV)** measures how the phase stability of a signal could change over an interval of duration T assuming that any constant frequency offset has been removed. Both TDEV and MTIE of a signal are compared to specific masks within ITU standards to verify clock quality.

**Ordinary clocks** have a single network port connection that can act as a master clock or slave clock.

**Boundary clocks** have multiple network port connections. Each port can be considered as an ordinary clock, where upstream ports are acting as a slave clock and downstream ports are acting as a master clock.

The **Grandmaster clock** is the root timing reference for the clocks residing on its network segment.

**Transparent clocks** measure the time taken for a PTP event message to transit the device and provide this information to ordinary clocks through modification of the event message correction field. The correction field will accumulate at every transparent clock in the network. Ordinary clocks use the correction field in their calculations to eliminate delay asymmetry. There are two types of transparent clock; End-to-end transparent clocks and Peer-to-peer transparent clocks

**End-to-end transparent clocks** update the event message correction field with the delay associated with individual packet transfers. This type of transparent clock supports the use of the end-to-end delay measurement mechanism between slave clocks and the master clock.

**Peer-to-peer transparent clocks** update the event message correction field with the line delay associated with the ingress transmission path as well as the PTP event message transit time. The peer delay mechanism operates between two adjacent peer-to-peer transparent clocks.

**Full on-path support** is a network where every node between the master clock and the slave clock is either a **boundary clock** or a **transparent clock**.

**Time Error (TE)** is the difference in the time indicated by two ordinary clocks at the same instant, and more specifically the difference between a master clock and a slave clock that is supposed to be synchronized to that master. Time Error can be decomposed into two components: Constant Time Error and Dynamic Time Error.

**Constant Time Error (cTE)** is the long term average of Time Error. It can be considered the basic measure of accuracy of a slave clock.

**Dynamic Time Error (dTE)** describes the noise component in Time Error, where  $dTE = TE - cTE$ . It can be considered a measure of the stability of a slave clock.

In a transparent clock, **Correction Field Accuracy** is the difference between the actual residence time for a 1588 event message and the time added to the correction field in the event message. It is the basic measure of accuracy of a transparent clock and is usually quoted in ns.

**Primary Reference Clock (PRC)** provides the highly accurate master clocks in a telecommunications network. Atomic clocks or GPS disciplined oscillators are normally used for the timing reference. In PTP networks these are often referred to as grandmasters.

**Best Master Clock Algorithm (BMCA)** is an algorithm run on slave clocks to select the optimal master clock. The primary algorithm is defined in the IEEE1588-2008 standard but alternate algorithms are allowed through the PTP profiles.

**PTP Profiles** have been created to define the set of allowed PTP features applicable to a device. The purpose of a PTP profile is to allow organizations to specify specific selections of attribute values and optional features of PTP that, when using the same transport protocol, inter-work and achieve a performance that meets the requirements of a particular application. Profiles already exist for the power industry and telecommunications networks.

**Sync Status Messages (SSM)** are used in SONET/SDH networks to select the primary reference clock, to avoid timing loops, to provide information about failover paths and to make sure that higher quality clocks are not slaved to lower quality clocks. Overhead bytes in the SONET/SDH transport are used to carry the SSM messages that include the clock quality and status information.

**Ethernet Synchronisation Messaging Channel (ESMC)** extends SSM messaging to Synchronous Ethernet to achieve interoperability with SDH equipment. SSM over Synchronous Ethernet is defined by the ITU-T in G.8264. The ESMC protocol is composed of the standard Ethernet header for a slow protocol, where the SSM values are encoded into a type length value (TLV) structure as described in ITU-T G.781.



Cambium Networks and the stylized circular logo are trademarks of Cambium Networks, Ltd. All other trademarks are the property of their respective owners.  
© Copyright 2015 Cambium Networks, Ltd.  
All rights reserved.

11/2015